

### Fuels Burned and Control Systems

- Natural Gas, Propane, Digester or Mixed Gases
- Light #2 Oil, Mechanical Pressure
- On-Off, Low Fire Start, Low-High-Low, Modulating or Micro Modulation
- Control Circuit Requires 120 vac, 60 Hz, Single Phase Voltage Supply

Check appropriate box to indicated selected version.

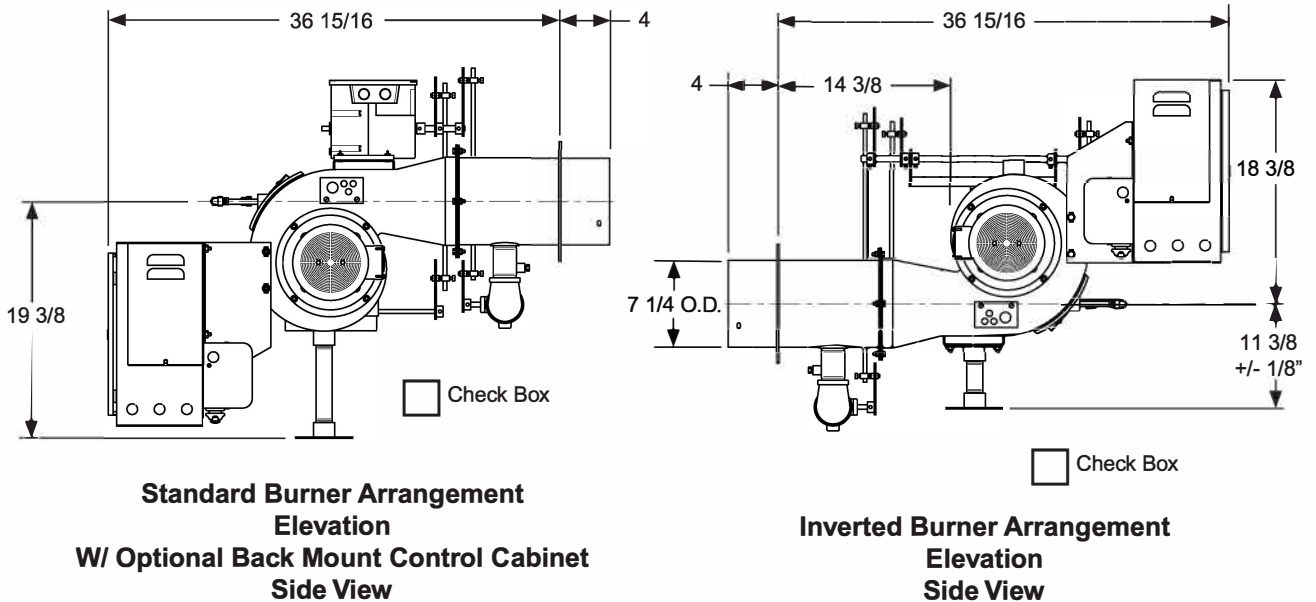
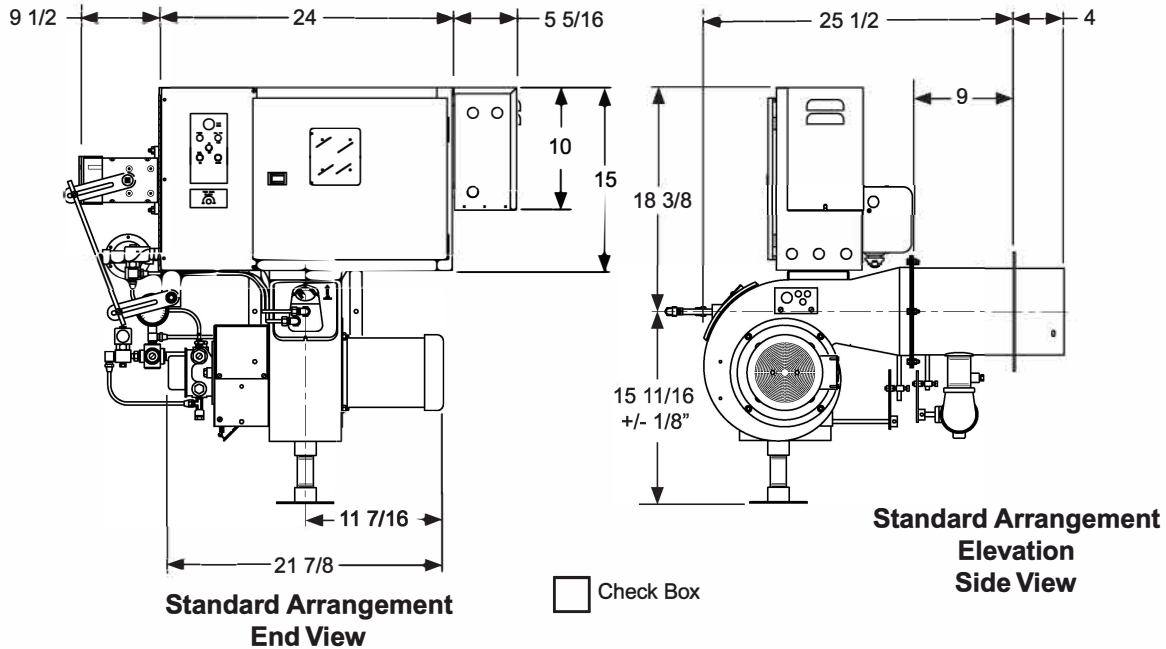

Model JB1 burners are listed by Underwriters Laboratories, Inc. (UL). Also by the State of Massachusetts Fire Marshal, City of New York Board of Standards and Appeals, State of Minnesota and can be packaged to meet specific requirements of IRI, FM, GE GAP, NFPA, MIL spec. or other special insurance or local code requirements.

1. STANDARD UL EQUIPMENT AND IMPORTANT OPTIONS		Fuel Burned		STANDARD UL EQUIPMENT AND IMPORTANT OPTIONS		Fuel Burned	
		Gas	No. 2 Oil pressure atomized			Gas	No. 2 Oil pressure atomized
General	Motor, Fan and Air Inlet Control	X	X	Gas Fuel	Main Manual Shutoff Valve	X	
	Air Flow Switch (also with oil systems using remote pump)	X			Main Safety Shutoff Valve	X	
	2. Burner Mounted Control Panel, Switch and Four Indicator Lights	X	X		Second Safety Shutoff Valve	X	
	Flame Safety Control	X	X		Main Gas Regulator	X	
	Ultra Violet Scanner	X	X		Gas Checking Valve	X	
	Motor Controller (single phase voltage)	X	X		High and Low Gas Pressure Switches (st'd over 2500 MBH)	Opt.	
	Fuel Selector Switch	Duel Fuel Burners Only			Metering Valve (modulation only)	X	
Ignition	Proven Gas Pilot Ignition	X		Oil Fuel	Oil Drawer Assembly with Diffuser		X
	Pilot Solenoid Gas Valve	X			Oil Nozzle(s)		X
	Pilot Gas Regulator & Manual Valve	X			Integral Oil Pump		X
	Pilot Gas Ignition Transformer	X			Main Safety Shutoff Valve		X
	Direct Spark Oil Ignition		X		Second Safety Shutoff Valve		X
	Direct Spark Oil Ignition Transformer		X		Low Oil Pressure Switch STD (when using remote oil pump)		Opt.
Optional	Inverted Housing	X	X	Oil Pressure Gauge		X	
	Alternate Control Cabinet Positioning	X	X	Oil Metering Valve (modulating systems)		X	
	Remote Control Panel	X	X	Future Gas Combustion Head-OPT		Opt.	
	Fuel Metering CAM-NETIC II	X	X				

- The configuration of each unit will vary with specific job requirements such as input rating, electrical specification and special agency approval codes. The above chart shows those items standard to a basic burner plus a few options that may be added.
- Indicator lights are "Power On", "Call for Heat", "Fuel On" and "Flame Fail".

**Model JB1 - Sizing and Application Data (contact Webster for complete information)**

Model Number	Maximum Furnace Pressure	Burner Firing Capability Range		Burner Motor HP		Gas Train			Oil Pump Motor HP
		Gas scfh	#2 Oil gph	Gas Only HP	1. Oil or Combination	Pipe Size	2. Inlet Pressure		
							On-Off, LFS	Modulation	
JB1-02	1.25	400 / 1000	3.0 / 7.1	1/4	1/3	1"	6 / 14"	7 / 14"	Integral
JB1-03	1.25	600 / 1500	4.0 / 10.7	1/3	1/2	1 1/4"	8 / 14"	9 / 14"	Integral
JB1-05	1.25	800 / 2100	6.0 / 14.8	1/2	1/2	1 1/2"	7 / 14"	8 / 14"	Integral
JB1-07	1.25	900 / 2500	7.0 / 17.8	3/4	3/4	1 1/2"	9 / 14"	11 / 14"	Integral

- Larger motors may be required for single phase or 208 volts
  - Contact Webster for more complete details
- The above maximum ratings are based on 0 furnace pressure, an altitude of 1000 feet, 90°F air temperature and 60 HZ electrical supply. Use the following corrections for higher temperatures and altitude. Capacity decreases by 17% for 50 Hertz.
- Capacity decreases by 4% for each 1000 feet above 1000 foot altitude.
  - Capacity decreases by 6% for each 1 inch of furnace pressure.
  - Capacity decreases by 2% for each 10°F increase in air temperature over 90°F.
- Gas input ratings based on 1000 BTU/cu ft. and 0.64 specific gravity. Sizes and pressure will vary with gas.  
 Oil input ratings are based on 140,000 BTU/gal for ASTM #2 fuel oil.

**Essential Ordering Information and Data:**

- Power Supply - Confirm 120-60-1 for control circuit and electrical supply for burner motor(s) (voltage, frequency and phase).
- Describe Boiler or Heater to be Fired - Including the manufacturer, model number, furnace pressure and furnace size.
- Firing Rate - Define firing rates in MBH for gas and GPH for oil.
- Fuel to be Burned - Type of gas and/or oil, including the BTU value.
- Approval Agency - UL, FM, IRI (GE GAP), CSD-1, NFPA, Mil spec and local codes, if applicable.
- Flame Safety Control Preferred - Honeywell or Fireye controls.
- Gas Train Components Preferred - ASCO/ITT, Honeywell or Landis
- Control System - ON-OFF, Low Fire Start, Low-High-Low, Modulation, Posi-Control
- Required Options - Mounting plate, limit controls, etc.