



# SABER HEAT RECOVERY STACK

(FOR HOT OIL HEATERS)

FEATURES	BENEFITS
SEAMLESS HELICAL COIL	CAPTURES EXHAUST HEAT SAVING EXTRA MONEY
STACK IS INSULATED	INSULATION KEEPS THE HEAT IN WHEN THE BURNER IS NOT RUNNING. DOESN'T CAUSE A "RADIATOR" EFFECT
BOLT ON DESIGN	ADDS ON TO OTHER BRANDS OF HOT OIL HEATER VERY EASILY



Call us toll free!

(888)333-0323



**Contact Information**  
Meeker Equipment Co., Inc.  
4381 Front Mountain Road  
Belleville, PA 17004  
Phone: (717)667-6000  
Fax: (717) 935-2389  
Email: [info@meekerequipment.com](mailto:info@meekerequipment.com)

[www.meekerequipment.com](http://www.meekerequipment.com)

# MEEKER

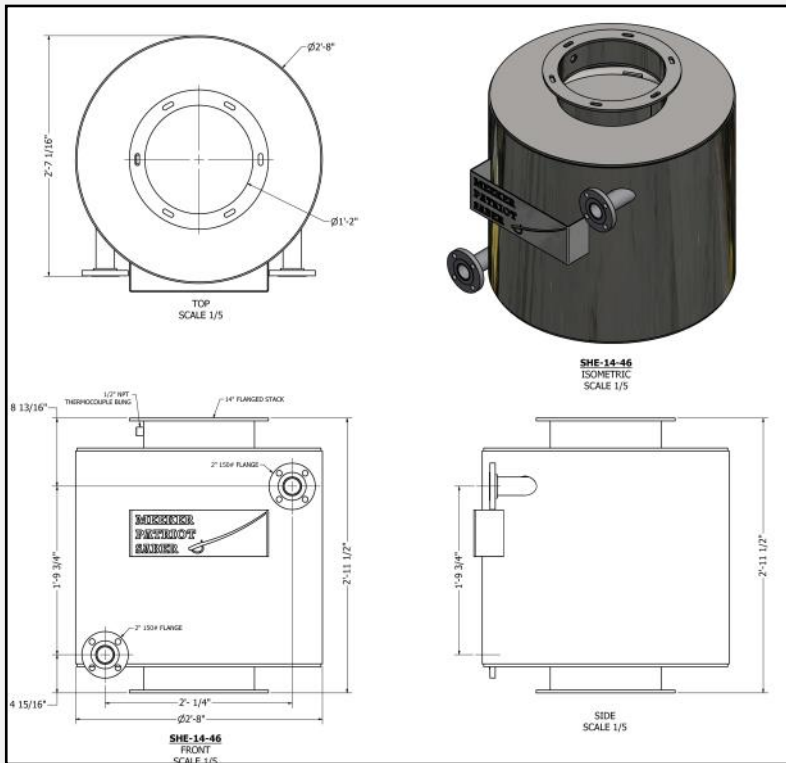

## MODEL SHE-14-46

FOR UP TO 2 MMBTU HOT OIL  
HEATERS

24 SQUARE FEET OF SURFACE

**MODEL SHE-14-92**  
FOR 3 TO 4 MMBTU HOT OIL  
HEATERS  
48 SQUARE FEET OF SURFACE

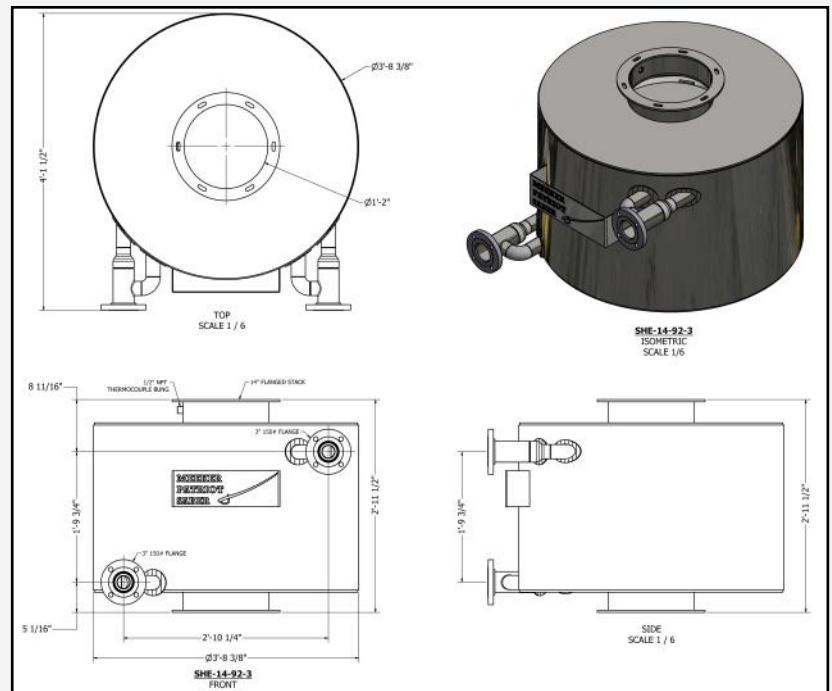

# MEEKER

Call us toll free!

(888)333-0323



[www.meekerequipment.com](http://www.meekerequipment.com)

**Contact Information**  
Meeker Equipment Co., Inc.  
4381 Front Mountain Road  
Belleville, PA 17004  
Phone: (717)667-6000  
Fax: (717) 935-2389  
Email: [info@meekerequipment.com](mailto:info@meekerequipment.com)