

CONSTRUCTION PARTS INC.®

P.O. BOX 31207
CLEVELAND, OHIO 44131

ORDER BY PHONE **TOLL FREE 1-800-222-1141**
Ohio 1-800-338-5608
FAX 216-524-5682 Telephone 216-524-7100

AVAILABLE REPLACEMENT PARTS
FOR
H&B PLANTS

MIXER PARTS

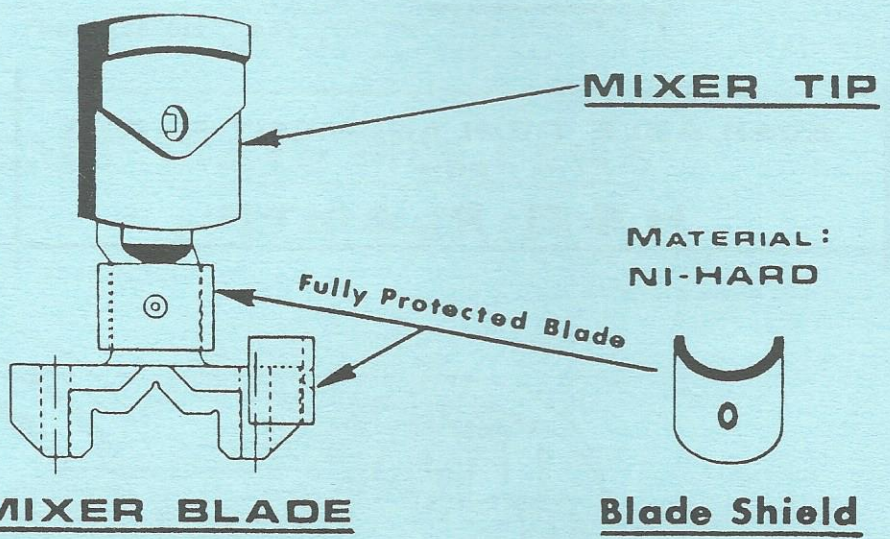
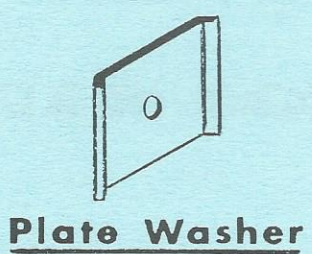

C.P.I. Part No.	Replacement For O.E.M. Part No.	Part Description	Mixer Model No.
<u>2,000 Lb. Mixers</u>			
SHK-3446-R	450-2-02103	R.H. Mixer Blade (Shank)	S-15
SHK-3446-L	450-2-02104	L.H. Mixer Blade (Shank)	H-20
TPS-3522	450-2-02084	Mixer Tip	S-25
MXP-7093	450-6-14511 (2480-B)	Plate Washer	S-25-A; S-30
MXP-7146		Blade Shield	
<u>4,000 Lb. Mixers</u>			
SHK-3800-R	450-2-02437	R.H. Mixer Blade (Shank)	S-40
SHK-3800-L	450-2-02438	L.H. Mixer Blade (Shank)	S-41
TPS-3525	450-2-02480 (4-006362)	Mixer Tip	S-41-A
MXP-7093	450-6-14511 (2480-B)	Plate Washer	SM-64-0
MXP-7146		Blade Shield	
<u>5/6,000 Lb. Mixers</u>			
SHK-3422-R	450-2-02466	R.H. Mixer Blade (Shank)	S-50
SHK-3422-L	450-2-02468	L.H. Mixer Blade (Shank)	S-50-A
TPS-3527	450-2-02467 (4-006015)	Mixer Tip	S-60
MXP-7094	450-6-14519 (2467-B)	Plate Washer	S-60-A
MXP-7223		Blade Shield	SM-85-0 SM-110-0
<u>8/10/12,000 Lb. Mixers</u>			
SHK-3423-R	450-2-06408 (4-006120)	R.H. Mixer Blade (Shank)	SM-129
SHK-3423-L	450-2-06409 (4-006247)	L.H. Mixer Blade (Shank)	SM-156
TPS-3529	450-2-16852 (4-006121)	Mixer Tip	SM-177
MXP-7095	450-6-14558	Plate Washer	SM-230
MXP-7225		Blade Shield	

"YOUR HEADQUARTERS FOR ASPHALT PLANT REPLACEMENT PARTS"

C ONSTRUCTION P ARTS I NC.®



ORDER
BY PHONE

TOLL FREE
1-800-222-1141

Ohio 1-800-338-5608

FAX 216-524-5682

Telephone 216-524-7100

AVAILABLE REPLACEMENT PARTS
FOR
H & B PLANTS

SHAFT SEALS

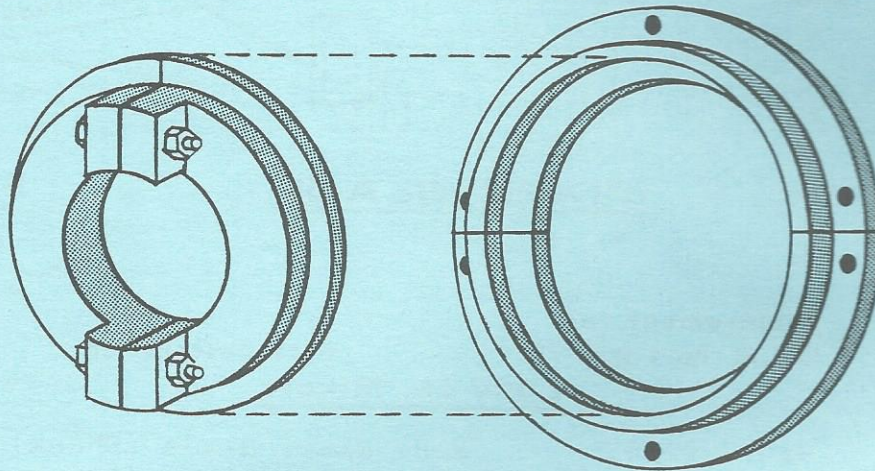

INNER SHAFT SEAL OUTER SHAFT SEAL

C.P.I. PART NO.	PART DESCRIPTION	REPLACEMENT FOR O.E.M. PART NO.
--------------------	------------------	------------------------------------

4000# Mixers

MXP-7012	Inner Shaft Seal	#450-6-02489
MXP-7013	Outer Shaft Seal	#450-6-02490

5000# - 6000# MIXERS

MXP-7014	Inner Shaft Seal	#450-6-02460 (#1-006190)
MXP-7015	Outer Shaft Seal	#450-6-02461 (#1-006189)

8000# thru 12,000# MIXERS

MXP-7016	Inner Shaft Seal	#450-6-06406 (#1-006028)
MXP-7017	Outer Shaft Seal	#450-6-02569 (#1-006027)

"YOUR HEADQUARTERS FOR ASPHALT PLANT REPLACEMENT PARTS"



ORDER
BY PHONE

TOLL FREE
1-800-222-1141

Ohio 1-800-338-5608

FAX 216-524-5682

Telephone 216-524-7100

REPLACEMENT GATE ROLLERS
H & B PLANTS

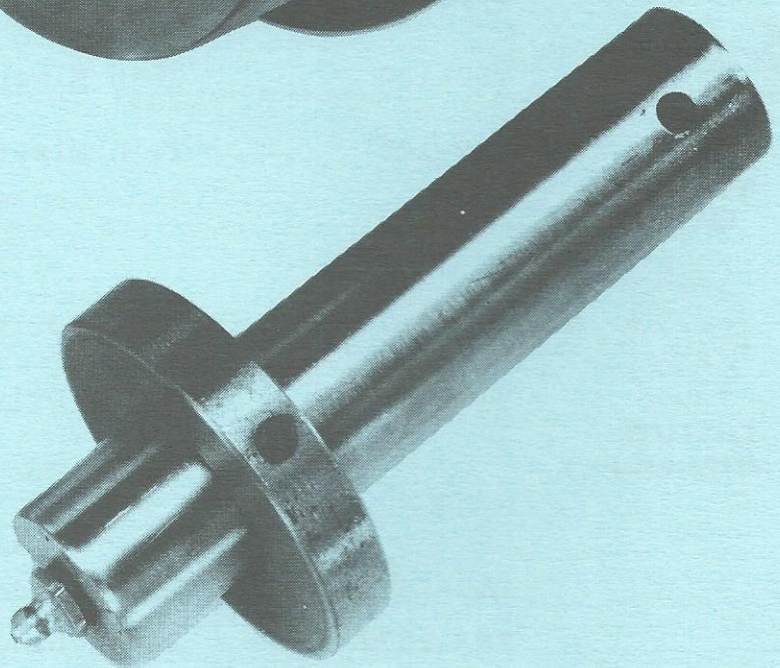
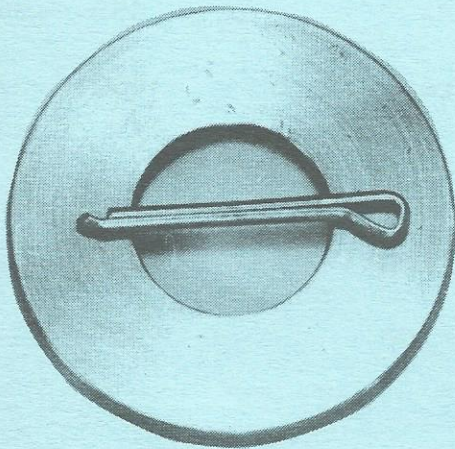
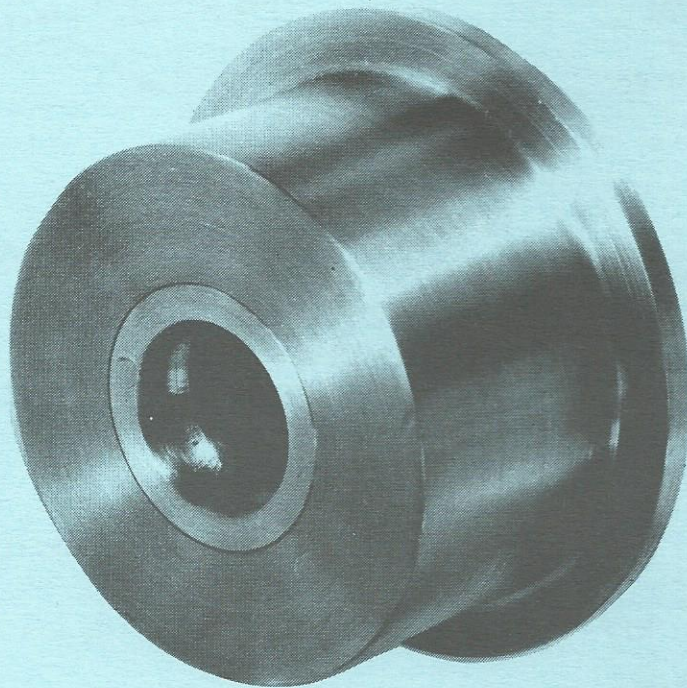

"YOUR HEADQUARTERS FOR ASPHALT PLANT REPLACEMENT PARTS"

ORDER BY PHONE **TOLL FREE**
1-800-222-1141
Ohio 1-800-338-5608
FAX 216-524-5682 Telephone 216-524-7100

AVAILABLE REPLACEMENT PARTS
FOR
H & B PLANTS

MIXER PARTS
MODELS: S-15; H-20;
S-25; S-25-A; S-30

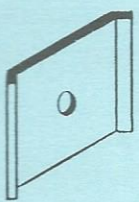
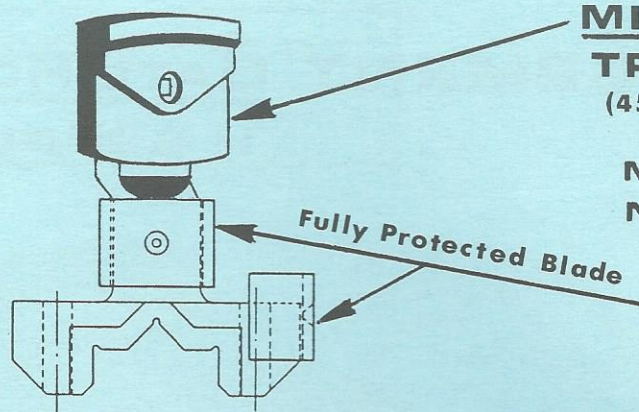

Plate Washer
MXP-7093
(450-6-14511)(2480-B)



MIXER TIP
TPS-3522
(450-2-02084)

MATERIAL:
NI-HARD



Blade Shield
MXP-7146
(Plug Welded To Blade)

MIXER BLADE
SHK-3446-R
(450-2-02103)
SHK-3447-L
(450-2-02104)

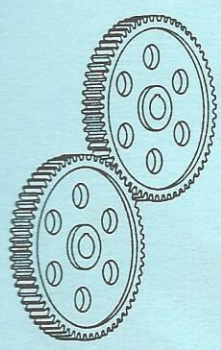

TIMING GEAR



DRIVE PINION

C.P.I. PART No.	PART DESCRIPTION	REPLACEMENT FOR O.E.M. PART No.
-----------------	------------------	---------------------------------

TRP-123	Twin Mixer Gears	450-4-02756
TRP-124	Twin Mixer Gears	450-4-06470
TRP-143	Twin Mixer Gears	450-4-02747
TRP-131	Mixer Drive Pinion	450-6-03187
TRP-140	Mixer Drive Pinion	450-6-03188

MIXER LINERS

LNR-2571	Lower Side Liner	450-2-15048
LNR-2572	Shell Liner	450-2-15049
LNR-2573	Gate Liner	450-2-15050

CONSTRUCTION
PARTS
INC.®

ORDER BY PHONE **TOLL FREE**
1-800-222-1141
Ohio 1-800-338-5608
FAX 216-524-5682 Telephone 216-524-7100

AVAILABLE REPLACEMENT PARTS
FOR
H & B PLANTS

MIXER PARTS
MODELS: SM-64-0;
S-40; S-41; S-41-A

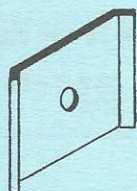
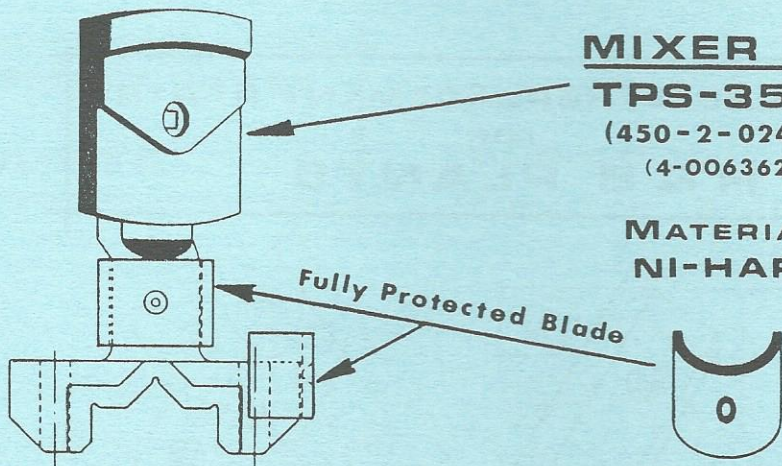

Plate Washer
MXP-7093
(450-6-14511)(2480-B)



MIXER TIP
TPS-3525
(450-2-02480)
(4-006362)

MATERIAL:
NI-HARD

MIXER BLADE
SHK-3800-R
(450-2-02437)
SHK-3800-L
(450-2-02438)

Blade Shield
MXP-7146
(Plug Welded To Blade)

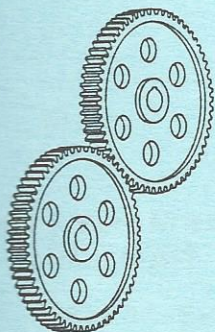

TIMING GEAR

C.P.I. PART No.	PART DESCRIPTION	REPLACEMENT FOR O.E.M. PART No.
-----------------	------------------	---------------------------------

TRP-141	Twin Mixer Gears	450-4-02763 (300-56-54)
---------	------------------	----------------------------



DRIVE PINION

TRP-130	Mixer Drive Pinion	450-6-02954
---------	--------------------	-------------

"YOUR HEADQUARTERS FOR ASPHALT PLANT REPLACEMENT PARTS"

C ONSTRUCTION P ARTS I NC.®



ORDER
BY PHONE

TOLL FREE
1-800-222-1141

Ohio 1-800-338-5608

FAX 216-524-5682

Telephone 216-524-7100

AVAILABLE REPLACEMENT PARTS
FOR
H & B PLANTS

MIXER LINERS MODEL No. SM-64-0

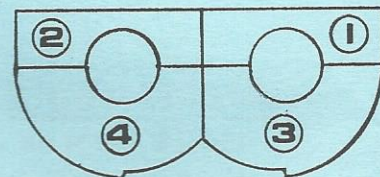
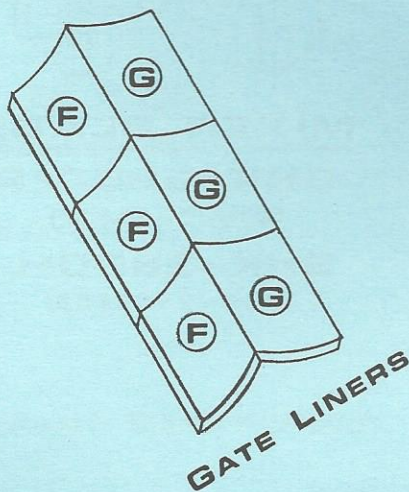
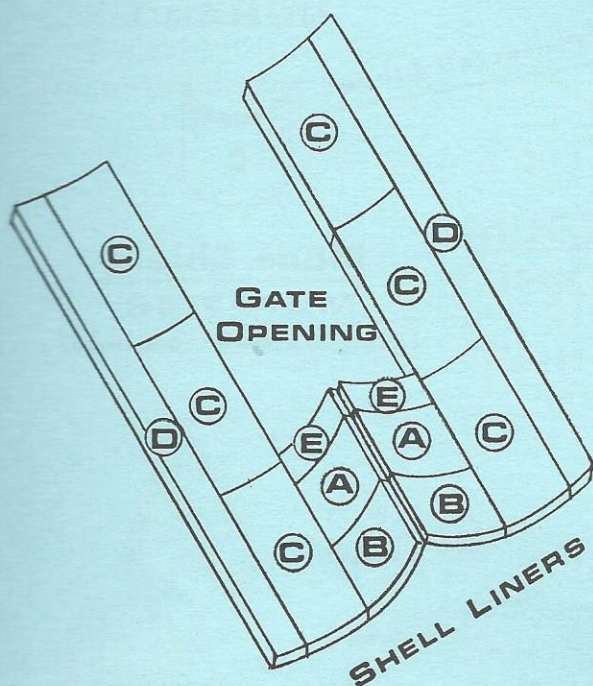

END LINERS

**MATERIAL:
NI-HARD**

REF.	C.P.I. PART No.	PART DESCRIPTION	REPLACEMENT FOR O.E.M. PART No.
A	LNR-2766	Shell Liner	450-2-16449
B	LNR-2201	Shell Liner	450-2-16451
C	LNR-2202	Shell Liner	450-2-16448
D	LNR-2203	Shell Liner	450-2-16468
E	LNR-2774	Slice Bar Liner	450-2-16452
F	LNR-2767	Gate Liner	450-2-16450
G	LNR-2775	Gate Liner	450-2-16457
1	LNR-2255	End Liner	450-6-16453
2	LNR-2256	End Liner	450-6-16454
3	LNR-2257	End Liner	450-6-16455
4	LNR-2258	End Liner	450-6-16456

"YOUR HEADQUARTERS FOR ASPHALT PLANT REPLACEMENT PARTS"

C ONSTRUCTION P ARTS I NC.®



ORDER
BY PHONE

TOLL FREE
1-800-222-1141

Ohio 1-800-338-5608

FAX 216-524-5682

Telephone 216-524-7100

AVAILABLE REPLACEMENT PARTS FOR H & B PLANTS

MIXER LINERS 3,000/4,000 LB. MIXER MODEL No. S-40; S-41

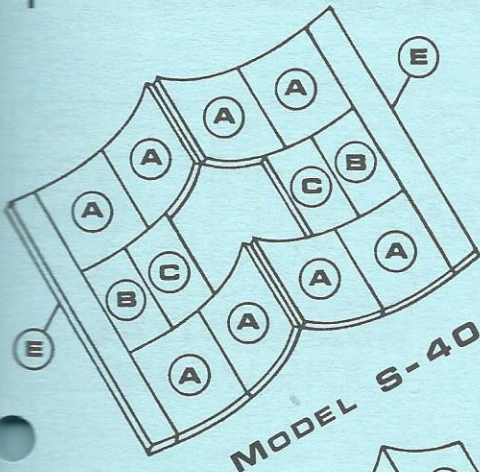

MODEL S-40

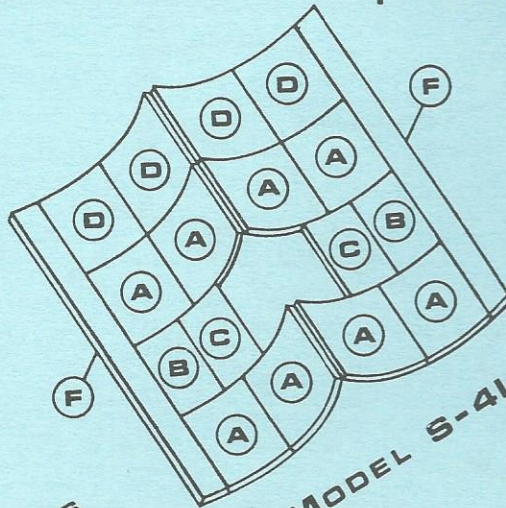

MODEL S-41



GATE LINERS

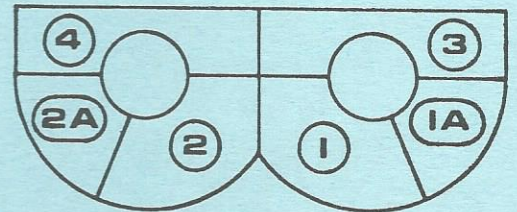

SEGMENTAL
END LINERS

MATERIAL:
NI-HARD

REF.	C.P.I. PART No.	PART DESCRIPTION	REPLACEMENT FOR O.E.M. PART No.
A	LNR-2189	Shell Liner	450-2-02576
B	LNR-2190	Shell Liner	450-2-02481
C	LNR-2191	Shell Liner	450-2-02482
D	LNR-2194	Shell Liner	450-2-06038
E	LNR-2192	Shell Liner	450-2-02769
F	LNR-2193	Shell Liner	450-2-06033
G	LNR-2221	Gate Liner	450-2-02484
1	LNR-2235	Split End Liner } Split End Liner }	Make-Up 450-2-02545-R
1A	LNR-2236		
2	LNR-2237	Split End Liner } Split End Liner }	Make-Up 450-2-02545-L (14512)
2A	LNR-2238		
3	LNR-2233	End Liner	450-2-02546-R
4	LNR-2234	End Liner	450-2-02546-L (14513)

"YOUR HEADQUARTERS FOR ASPHALT PLANT REPLACEMENT PARTS"

C O N S T R U C T I O N P A R T S I N C .[®]



ORDER
BY PHONE

TOLL FREE
1-800-222-1141

Ohio 1-800-338-5608

FAX 216-524-5682

Telephone 216-524-7100

**AVAILABLE REPLACEMENT PARTS
FOR
H & B PLANTS**

MIXER LINERS

4,000 LB. MIXER
MODEL NO. S-41-A

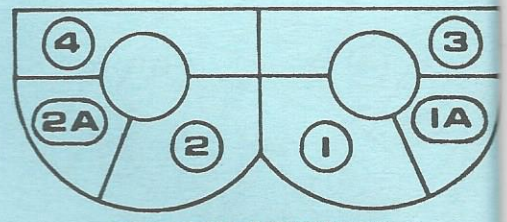
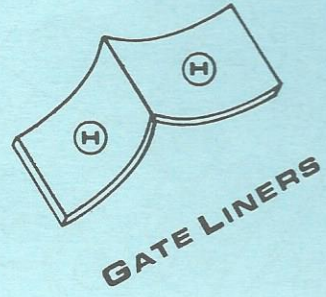
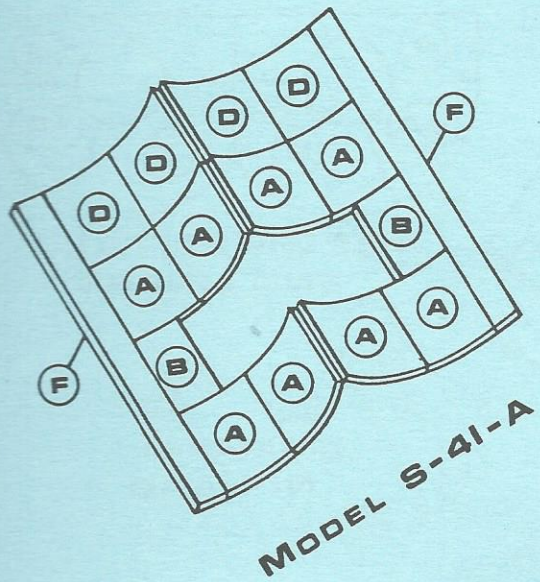

**SEGMENTAL
END LINERS**

**MATERIAL:
NI-HARD**

REF.	C.P.I. PART NO.	PART DESCRIPTION	REPLACEMENT FOR O.E.M. PART NO.
A	LNR-2189	Shell Liner	450-2-02576
B	LNR-2190	Shell Liner	450-2-02481
D	LNR-2194	Shell Liner	450-2-06038
F	LNR-2193	Shell Liner	450-2-06033
H	LNR-2570	Gate Liner	450-2-06485
1	LNR-2235	Split End Liner } Split End Liner }	450-2-02545-R
1A	LNR-2236		
2	LNR-2237	Split End Liner } Split End Liner }	450-2-02545-L (14512)
2A	LNR-2238		
3	LNR-2233	End Liner	450-2-02546-R
4	LNR-2234	End Liner	450-2-02546-L (14513)

"YOUR HEADQUARTERS FOR ASPHALT PLANT REPLACEMENT PARTS"

C ONSTRUCTION

P ARTS

I NC. ®



ORDER
BY PHONE

TOLL FREE
1-800-222-1141

Ohio 1-800-338-5608

FAX 216-524-5682

Telephone 216-524-7100

AVAILABLE REPLACEMENT PARTS
FOR
H & B PLANTS

MIXER PARTS
MODELS: S-50; S-50-A;
S-60; S-60-A;
SM-85-0; SM-110-0

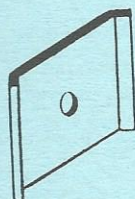
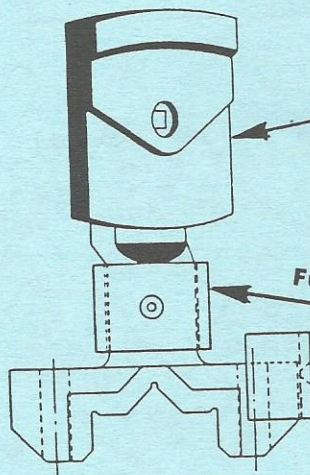

Plate Washer
MXP-7094
(450-6-14519) (2467-B)



MIXER BLADE
SHK-3422-R
(450-2-02466)
SHK-3422-L
(450-2-02468)

MIXER TIP
TPS-3527
(450-2-02467)
(4-006015)
MATERIAL:
NI-HARD

Fully Protected Blade



Blade Shield
MXP-7223
(Plug Welded To Blade)

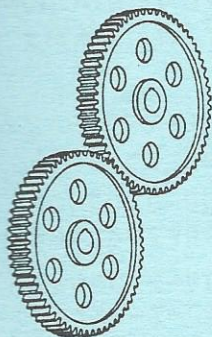

C.P.I. PART No.	PART DESCRIPTION	REPLACEMENT FOR O.E.M. PART No.
TRP-132	Twin Mixer Gears	450-4-02748

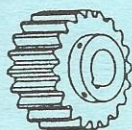

TRP-127	Mixer Drive Pinion	450-6-03149
---------	--------------------	-------------

"YOUR HEADQUARTERS FOR ASPHALT PLANT REPLACEMENT PARTS"

C O N S T R U C T I O N P A R T S I N C. ®



ORDER
BY PHONE

TOLL FREE
1-800-222-1141

Ohio 1-800-338-5608

FAX 216-524-5682

Telephone 216-524-7100

AVAILABLE REPLACEMENT PARTS
FOR
H & B PLANTS

MIXER LINERS
5,000 LB. MIXER
MODEL No. S-50; S-50-A

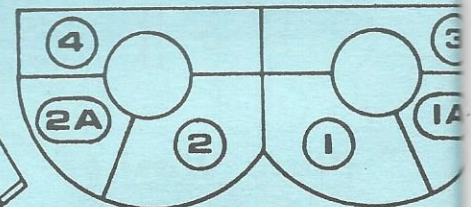
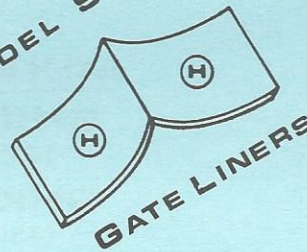
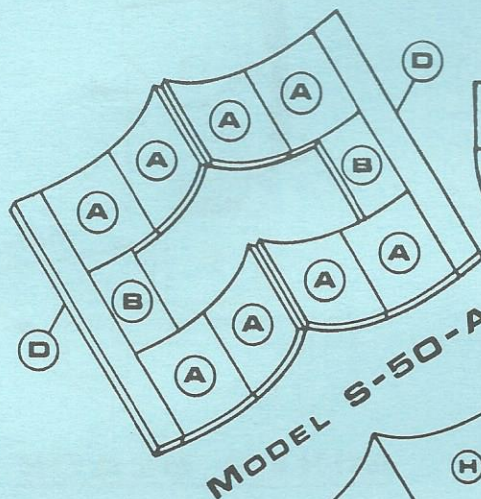
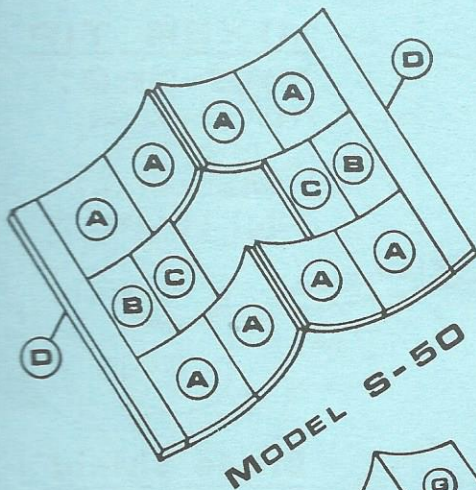

**SEGMENTAL
END LINERS**

**MATERIAL:
NI-HARD**

REF.	C.P.I. PART No.	PART DESCRIPTION	REPLACEMENT O.E.M. PART No.
A	LNR-2195	Shell Liner	450-2-02552
B	LNR-2196	Shell Liner	450-2-02536
C	LNR-2197	Shell Liner	450-2-02537
D	LNR-2198	Shell Liner	450-2-02768
G	LNR-2222	Gate Liner	450-2-02548
H	LNR-2223	Gate Liner	450-2-06449
1	LNR-2648	Split End Liner } Split End Liner }	450-2-02669-R
1A	LNR-2649		
2	LNR-2650	Split End Liner } Split End Liner }	450-2-02669-L
2A	LNR-2651		
3	LNR-2245	End Liner	450-2-02668-R
4	LNR-2246	End Liner	450-2-02668-L

"YOUR HEADQUARTERS FOR ASPHALT PLANT REPLACEMENT PARTS"

C O N S T R U C T I O N P A R T S I N C. ®



ORDER
BY PHONE

TOLL FREE
1-800-222-1141

Ohio 1-800-338-5608

FAX 216-524-5682

Telephone 216-524-7100

AVAILABLE REPLACEMENT PARTS FOR H & B PLANTS

MIXER LINERS 6,000 Lb. MIXER MODEL No. S-60; S-60-A

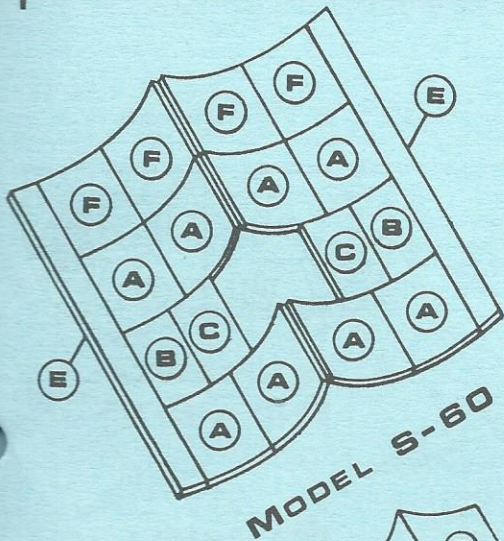

MODEL S-60

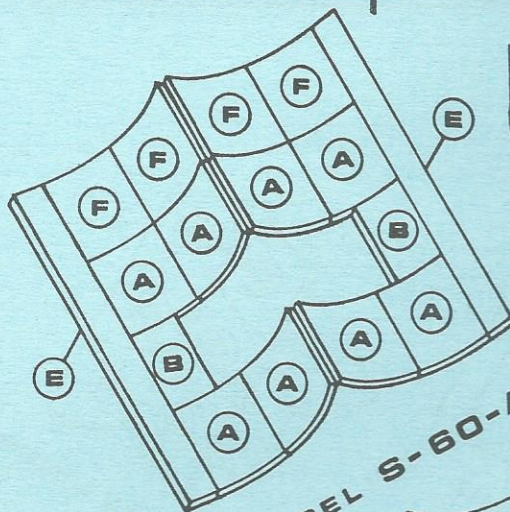

MODEL S-60-A

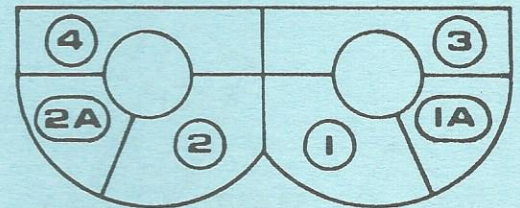

SEGMENTAL
END LINERS



GATE LINERS

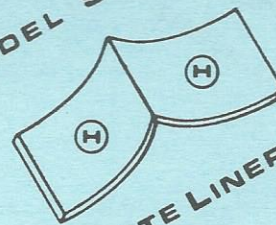

GATE LINERS

**MATERIAL:
NI-HARD**

REF.	C.P.I. PART No.	PART DESCRIPTION	REPLACEMENT FOR O.E.M. PART No.
A	LNR-2195	Shell Liner	450-2-02552
B	LNR-2196	Shell Liner	450-2-02536
C	LNR-2197	Shell Liner	450-2-02537
E	LNR-2199	Shell Liner	450-2-03682
F	LNR-2200	Shell Liner	450-2-03681
G	LNR-2222	Gate Liner	450-2-02548
H	LNR-2223	Gate Liner	450-2-06449
1	LNR-2648	Split End Liner	450-2-02669-R
1A	LNR-2649	Split End Liner	
2	LNR-2650	Split End Liner	450-2-02669-L
2A	LNR-2651	Split End Liner	
3	LNR-2245	End Liner	450-2-02668-R
4	LNR-2246	End Liner	450-2-02668-L

"YOUR HEADQUARTERS FOR ASPHALT PLANT REPLACEMENT PARTS"

C O N S T R U C T I O N P A R T S I N C. ®



ORDER
BY PHONE

TOLL FREE
1-800-222-1141

Ohio 1-800-338-5608

FAX 216-524-5682

Telephone 216-524-7100

AVAILABLE REPLACEMENT PARTS
FOR
H & B PLANTS

MIXER LINERS

5,000 LB. MIXER
MODEL No. SM-85-0

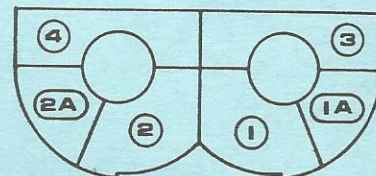
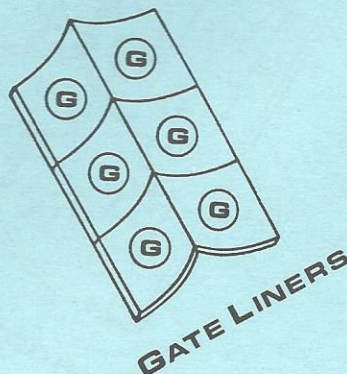
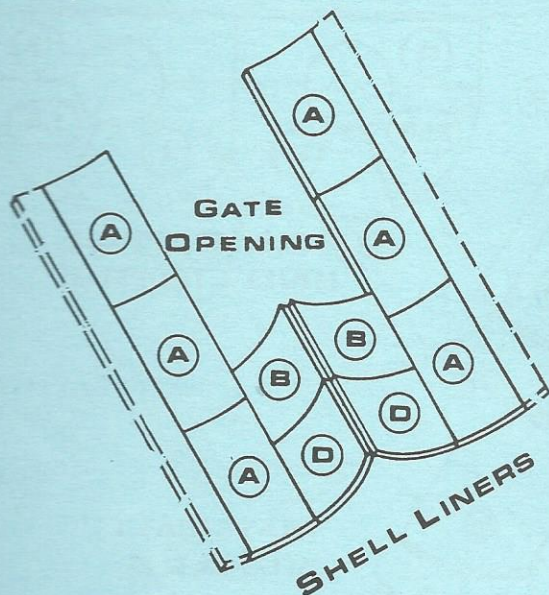

**SEGMENTAL
END LINERS**

**MATERIAL:
NI-HARD**

REF.	C.P.I. PART No.	PART DESCRIPTION	REPLACEMENT FOR O.E.M. PART No.
A	LNR-2204	Shell Liner	450-2-16340
B	LNR-2205	Shell Liner	450-2-16349
	LNR-2206	Shell Liner	450-2-16323
D	LNR-2207	Shell Liner	450-2-16341
G	LNR-2225	Gate Liner	450-2-16321
1	LNR-2655	Split End Liner	Make-Up 450-2-16342 (3-005708)
1A	LNR-2656	Split End Liner	
2	LNR-2657	Split End Liner	Make-Up 450-2-16343 (3-005709)
2A	LNR-2658	Split End Liner	
3	LNR-2653	End Liner	450-2-16366 (3-005707)
4	LNR-2654	End Liner	450-2-16365 (3-005706)

"YOUR HEADQUARTERS FOR ASPHALT PLANT REPLACEMENT PARTS"

C O N S T R U C T I O N P A R T S I N C. ®



ORDER
BY PHONE

TOLL FREE
1-800-222-1141

Ohio 1-800-338-5608

FAX 216-524-5682

Telephone 216-524-7100

AVAILABLE REPLACEMENT PARTS
FOR
H & B PLANTS

MIXER LINERS

6,000 LB. MIXER
MODEL No. SM-110-0

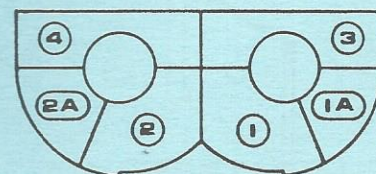
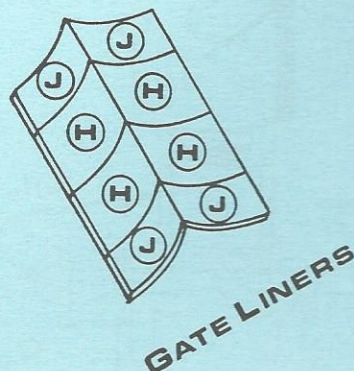
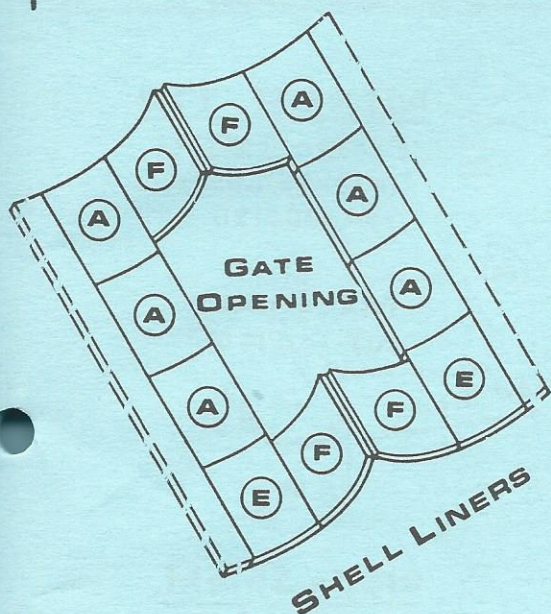

**SEGMENTAL
END LINERS**

**MATERIAL:
NI-HARD**

REF.	C.P.I. PART No.	PART DESCRIPTION	REPLACEMENT FOR O.E.M. PART No.
A	LNR-2204	Shell Liner	450-2-16340
	LNR-2206	Shell Liner	450-2-16323
E	LNR-2208	Shell Liner	450-2-16415 (3-005715)
F	LNR-2209	Shell Liner	450-2-16417 (3-005714)
H	LNR-2226	Gate Liner	450-2-16862 (4-006015)
J	LNR-2227	Gate Liner	450-2-16416
1	LNR-2655	Split End Liner	Make-Up 450-2-16342 (3-005708)
1A	LNR-2656	Split End Liner	
2	LNR-2657	Split End Liner	Make-Up 450-2-16343 (3-005709)
2A	LNR-2658	Split End Liner	
3	LNR-2653	End Liner	450-2-16366 (3-005707)
4	LNR-2654	End Liner	450-2-16365 (3-005706)

"YOUR HEADQUARTERS FOR ASPHALT PLANT REPLACEMENT PARTS"

C O N S T R U C T I O N P A R T S I N C .[®]

ORDER BY PHONE **TOLL FREE**
1-800-222-1141
 Ohio 1-800-338-5608
FAX 216-524-5682 Telephone 216-524-7100

**AVAILABLE REPLACEMENT PARTS
FOR
H & B PLANTS**

MIXER PARTS
MODELS: SM-129;
SM-156; SM-177;
SM-230

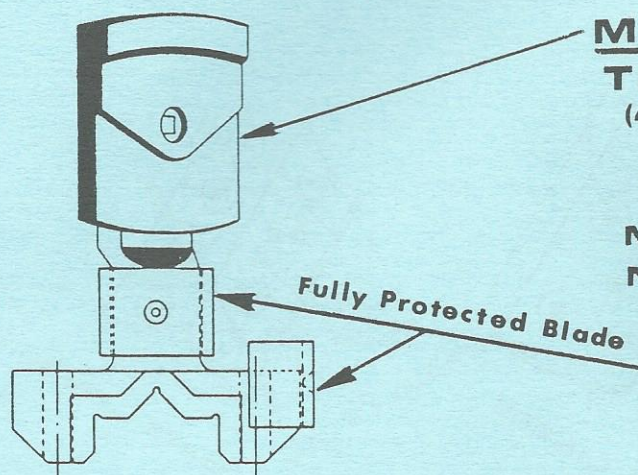
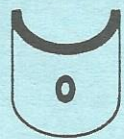

Plate Washer
MXP-7095
 (450-6-14558)



MIXER TIP
TPS-3529
 (450-2-16852)
 (4-006121)

MATERIAL:
NI-HARD

Fully Protected Blade



MIXER BLADE
SHK-3423-R
 (450-2-06408)
 (4-006120)
SHK-3423-L
 (450-2-06409)
 (4-006247)

Blade Shield
MXP-7225
 (Plug Welded To Blade)

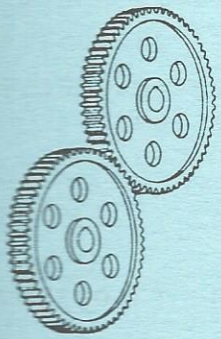

C.P.I. PART No.	PART DESCRIPTION	REPLACEMENT FOR O.E.M. PART No.
TIMING GEAR		
TRP-125	Twin Mixer Gears	450-4-06405
TRP-135	Twin Mixer Gears	450-4-02764

C O N S T R U C T I O N P A R T S I N C. ®



ORDER
BY PHONE

TOLL FREE
1-800-222-1141

Ohio 1-800-338-5608

FAX 216-524-5682

Telephone 216-524-7100

AVAILABLE REPLACEMENT PARTS
FOR
H & B PLANTS

MIXER LINERS

8,000 LB. MIXERS
MODEL NO. SM-129-0
RM-135-0

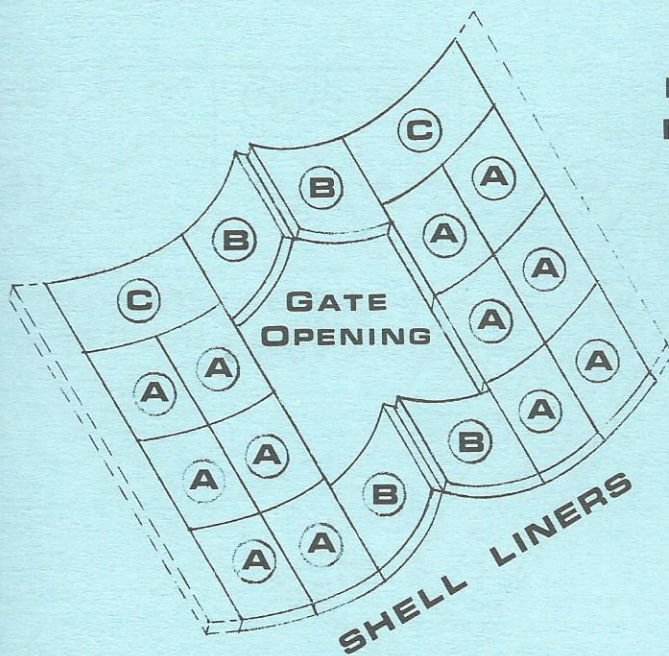

MATERIAL:
NI-HARD

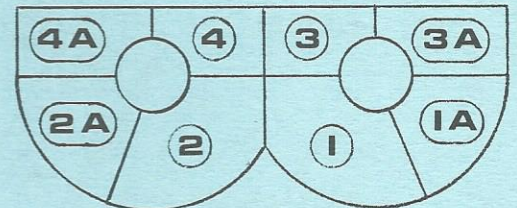

SEGMENTAL
END LINERS

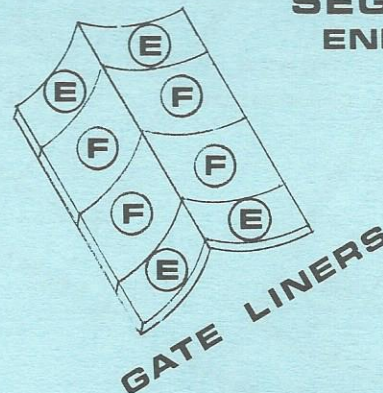

REF.	C.P.I. PART No.	PART DESCRIPTION		REPLACEMENT FOR O.E.M. PART No.
A	LNR-2210	Shell Liner		450-2-16482 (3-005638)
B	LNR-2212	Shell Liner		450-2-16484 (3-005642)
C	LNR-2213	Shell Liner		450-2-16488 (3-005641)
E	LNR-2215	Gate. Ext. Liner		450-2-16538 (3-005639)
F	LNR-2229	Gate Liner		450-2-16863 (3-006116)
1	LNR-2287	Split End Liner	} Make-Up	450-2-16492 (3-005564)
1A	LNR-2288	Split End Liner		
2	LNR-2289	Split End Liner	} Make-Up	450-2-16493 (3-005565)
2A	LNR-2290	Split End Liner		
3	LNR-2505	Split End Liner	} Make-Up	450-2-16490 (3-005566)
3A	LNR-2506	Split End Liner		
4	LNR-2507	Split End Liner	} Make-Up	450-2-16491 (3-005577)
4A	LNR-2508	Split End Liner		

"YOUR HEADQUARTERS FOR ASPHALT PLANT REPLACEMENT PARTS"

C O N S T R U C T I O N P A R T S I N C. ®

ORDER BY PHONE **TOLL FREE**
1-800-222-1141
 Ohio 1-800-338-5608
 FAX 216-524-5682 Telephone 216-524-7100

**AVAILABLE REPLACEMENT PARTS
FOR
H & B PLANTS**

**MIXER LINERS
10,000 LB. MIXERS
MODEL No. SM-156-0**

**MATERIAL:
NI-HARD**

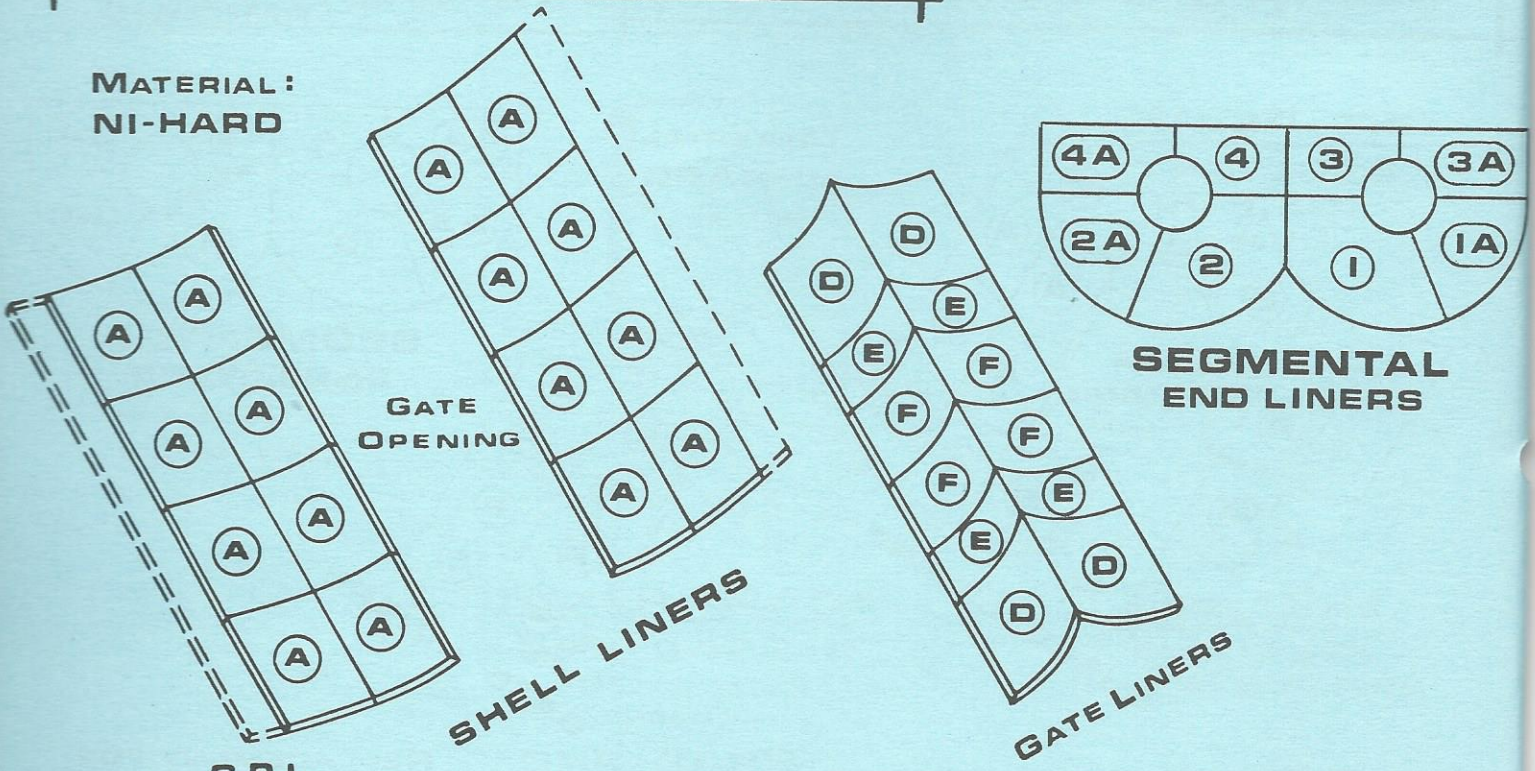

REF.	C.P.I. PART No.	PART DESCRIPTION	REPLACEMENT FOR O.E.M. PART No.	
A	LNR-2210	Shell Liner	450-2-16482	(3-005638)
D	LNR-2228	Gate Liner	450-2-16486/87	(3-005637)
E	LNR-2215	Gate Ext. Liner	450-2-16538	(3-005639)
F	LNR-2229	Gate Liner	450-2-16863	(3-006116)
1	LNR-2287	Split End Liner	Make-Up 450-2-16492	(3-005564)
1A	LNR-2288	Split End Liner		
2	LNR-2289	Split End Liner	Make-Up 450-2-16493	(3-005565)
2A	LNR-2290	Split End Liner		
3	LNR-2505	Split End Liner	Make-Up 450-2-16490	(3-005566)
3A	LNR-2506	Split End Liner		
4	LNR-2507	Split End Liner	Make-Up 450-2-16491	(3-005577)
4A	LNR-2508	Split End Liner		

"YOUR HEADQUARTERS FOR ASPHALT PLANT REPLACEMENT PARTS"

C ONSTRUCTION P ARTS I NC.®



ORDER
BY PHONE

TOLL FREE
1-800-222-1141

Ohio 1-800-338-5608

FAX 216-524-5682

Telephone 216-524-7100

AVAILABLE REPLACEMENT PARTS
FOR
H & B PLANTS

MIXER LINERS

12,000/16,000 LB. MIXERS
MODEL No. SM-177-0

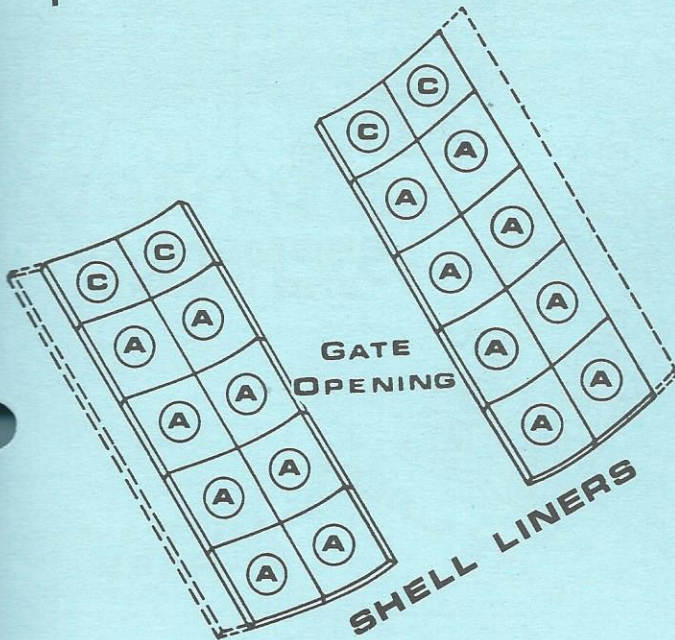

SHELL LINERS

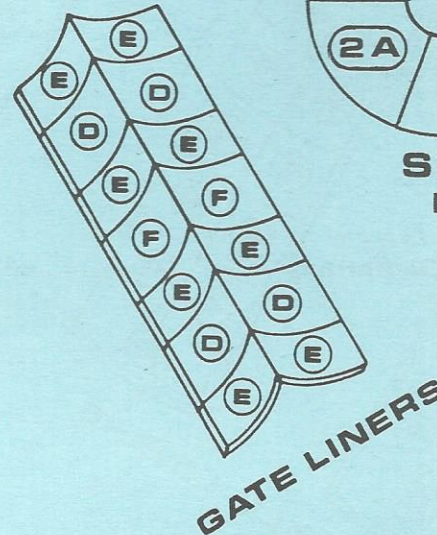

GATE LINERS

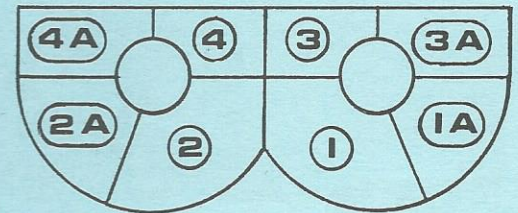

**SEGMENTAL
END LINERS**

**MATERIAL:
NI-HARD**

REF.	C.P.I. PART No.	PART DESCRIPTION	REPLACEMENT FOR O.E.M. PART No.
A	LNR-2210	Shell Liner	450-2-16482 (3-005638)
C	LNR-2219	Shell Liner	450-2-16540
D	LNR-2228	Gate Liner	450-2-16486/87 (3-005637)
E	LNR-2215	Gate Ext. Liner	450-2-16538 (3-005639)
F	LNR-2229	Gate Liner	450-2-16863 (3-006116)
1	LNR-2287	Split End Liner	Make-Up 450-2-16492 (3-005564)
1A	LNR-2288	Split End Liner	
2	LNR-2289	Split End Liner	Make-Up 450-2-16493 (3-005565)
2A	LNR-2290	Split End Liner	
3	LNR-2505	Split End Liner	Make-Up 450-2-16490 (3-005566)
3A	LNR-2506	Split End Liner	
4	LNR-2507	Split End Liner	Make-Up 450-2-16491 (3-005577)
4A	LNR-2508	Split End Liner	

"YOUR HEADQUARTERS FOR ASPHALT PLANT REPLACEMENT PARTS"

C ONSTRUCTION P ARTS I NC.®



ORDER
BY PHONE

TOLL FREE
1-800-222-114

Ohio 1-800-338-560

FAX 216-524-5682

Telephone 216-524-710

AVAILABLE REPLACEMENT PARTS
FOR
H & B PLANTS

MIXER LINERS
12,000/16,000 LB. MIXER
MODEL No. SM-230-0

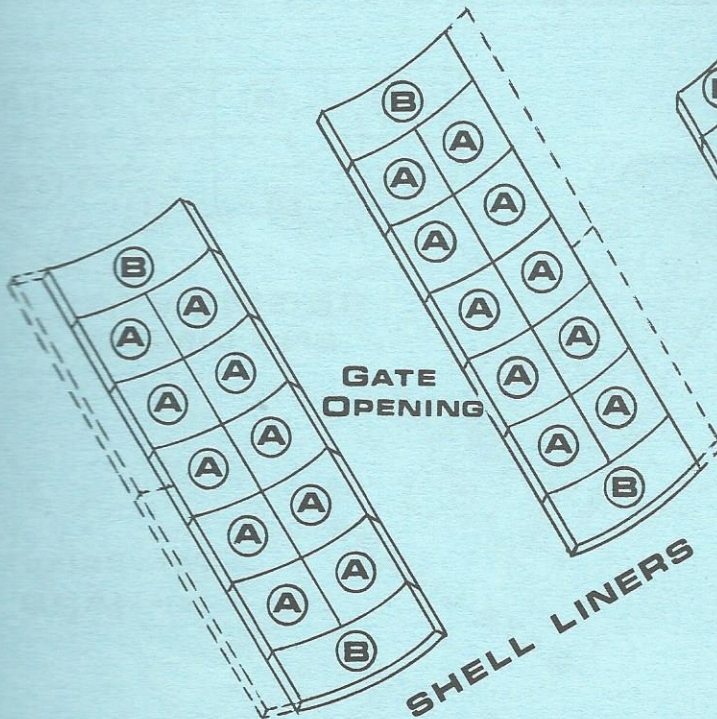

SHELL LINERS

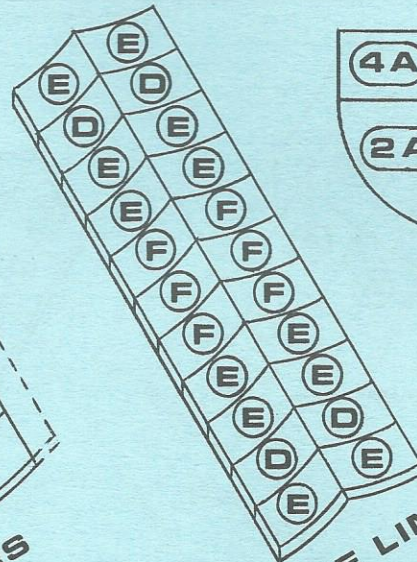

GATE LINERS

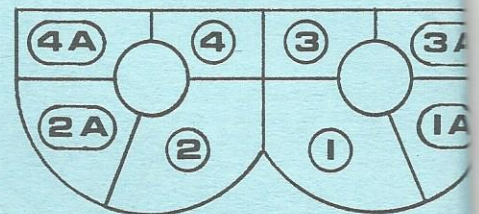

**SEGMENTAL
END LINERS**

**MATERIAL:
NI-HARD**

REF.	C.P.I. PART No.	PART DESCRIPTION	REPLACEMENT FOR O.E.M. PART No.
A	LNR-2210	Shell Liner	450-2-16482 (3-005638)
B	LNR-2213	Shell Liner	450-2-16488 (3-005641)
D	LNR-2228	Gate Liner	450-2-16486/87 (3-005637)
E	LNR-2215	Gate Ext. Liner	450-2-16538 (3-005639)
F	LNR-2229	Gate Liner	450-2-16863 (3-006116)
1	LNR-2287	Split End Liner	Make-Up 450-2-16492 (3-005564)
1A	LNR-2288	Split End Liner	
2	LNR-2289	Split End Liner	Make-Up 450-2-16493 (3-005565)
2A	LNR-2290	Split End Liner	
3	LNR-2505	Split End Liner	Make-Up 450-2-16490 (3-005566)
3A	LNR-2506	Split End Liner	
4	LNR-2507	Split End Liner	Make-Up 450-2-16491 (3-005577)
4A	LNR-2508	Split End Liner	

"YOUR HEADQUARTERS FOR ASPHALT PLANT REPLACEMENT PARTS"



ORDER
BY PHONE

TOLL FREE
1-800-222-1141

Ohio 1-800-338-5608

FAX 216-324-5882

Telephone 216-324-7100

DRYER PARTS

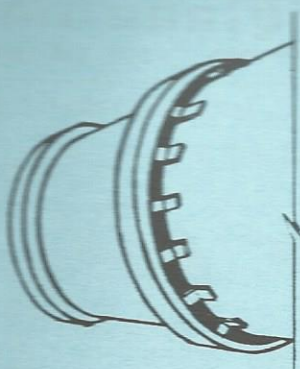

TRUNNION RING (Dryer Tire)

C.P.I. PART No.	PART DESCRIPTION	REPLACEMENT FOR O.E.M. PART No.
DRP-4125	Trunnion Ring	050-6-06456
DRP-4119	Truunion Ring	050-6-15922
DRP-4123	Trunnion Ring	050-6-02472
DRP-4130	Trunnion Ring	050-6-06389
DRP-4126	Trunnion Ring	050-6-03824
DRP-4122	Trunnion Ring	#2-005114
DRP-4131	Trunnion Ring	050-6-15091
DRP-4129	Trunnion Ring	050-6-15085

To Obtain Quote.....
(Need following information)

- _____ O.D. Dryer Tire
- _____ I.D. Dryer Tire
- _____ Width (Dryer Tire)

DRYER TRUNNIONS

Dimensions needed to obtain Quote.

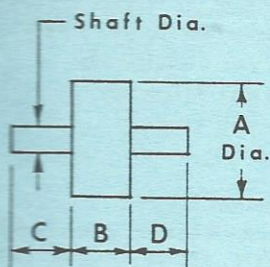

- A _____ Trunnion Diameter
- B _____ Trunnion Face (Width)
- C _____ Shaft Projection
- D _____ Shaft Projection

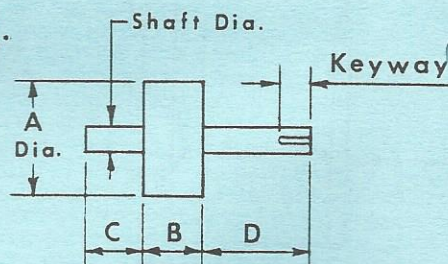

PLAIN TRUNNION
(For Gear Drive)

PLAIN TRUNNION
(For Trunnion Drive)

C.P.I. PART No.	PART DESCRIPTION	REPLACEMENT FOR O.E.M. PART No.
DRP-4201	Trunnion Roll Assembly	050-6-06461
DRP-4204	Trunnion Roll Assembly	050-6-06462
DRP-4206	Trunnion Roll Assembly	050-6-15034
DRP-4207	Trunnion Roll Assembly	050-6-15035
DRP-4210	Trunnion Roll Assembly	050-6-06382
DRP-4213	Trunnion Roll Assembly	050-6-15762
DRP-4219	Trunnion Roll Assembly	050-6-06402
DRP-4223	Trunnion Roll Assembly	050-6-15038
DRP-4226	Trunnion Roll Assembly	050-6-16119
DRP-4230	Trunnion Roll	050-6-15055
DRP-4231	Trunnion Roll Shaft	050-6-16117
DRP-4232	Trunnion Roll	050-6-15083
DRP-4233	Trunnion Roll Shaft	050-6-15088
DRP-4234	Trunnion Roll Shaft	050-6-15089

"YOUR HEADQUARTERS FOR ASPHALT PLANT REPLACEMENT PARTS"

CONSTRUCTION

PARTS

INC.®



ORDER
BY PHONE

TOLL FREE

1-800-222-1141

Ohio 1-800-338-5608

FAX 216-524-5682

Telephone 216-524-7100

AVAILABLE REPLACEMENT PARTS
FOR
H & B PLANTS

54" & 60" DRYERS

C.P.I. PART NO.	PART DESCRIPTION	REPLACEMENT FOR O.E.M. PART NO.
DRP-4125	Trunnion Ring (Dryer Tire)	050-6-06456
DRP-4119	Trunnion Ring (Dryer Tire)	050-6-15922
DRP-4201	Trunnion Roll Assembly Consists Of:	050-6-06461
	DRP-4202 Trunnion Roll	050-6-06455
	DRP-4203 Trunnion Roll Shaft	050-6-06453
DRP-4204	Trunnion Roll Assembly Consists Of:	050-6-06462
	DRP-4202 Trunnion Roll	050-6-06455
	DRP-4205 Trunnion Roll Shaft	050-6-06454
DRP-4206	Trunnion Roll Assembly	050-6-15034
DRP-4207	Trunnion Roll Assembly	050-6-15035
DRP-4208	Trunnion Roll	050-6-02620
DRP-4209	Trunnion Roll	050-6-03124
TRP-160	Ring Gear	050-6-06488
TRP-161	Drive Pinion	050-6-14889
TRP-162	Ring Gear	050-6-02511
TRP-163	Drive Pinion	050-6-02510
TRP-164	Drive Pinion	050-6-02584
TRP-165	Drive Pinion	050-6-02532

"YOUR HEADQUARTERS FOR ASPHALT PLANT REPLACEMENT PARTS"



ORDER
BY PHONE

TOLL FREE
1-800-222-1141

Ohio 1-800-338-5608

FAX 216-524-5682

Telephone 216-524-7100

AVAILABLE REPLACEMENT PARTS
FOR
H & B PLANTS

70" & 76" DRYER

C.P.I. PART NO.	PART DESCRIPTION	REPLACEMENT FOR O.E.M. PART NO.
DRP-4123	Truunion Ring (Dryer Tire)	050-6-02472
DRP-4130	Trunnion Ring (Dryer Tire)	050-6-06389
DRP-4210	Trunnion Roll Assembly Consists Of:	050-6-06382
	DRP-4211 Trunnion Roll	050-6-02473
	DRP-4212 Trunnion Roll Shaft	050-6-03647
DRP-4213	Trunnion Roll Assembly Consists Of:	050-6-15762
	DRP-4214 Trunnion Roll	050-6-14612
	DRP-4215 Trunnion Roll Shaft	050-6-14613
DRP-4219	Trunnion Roll Assembly Consists Of:	050-6-06402
	DRP-4220 Trunnion Roll	050-6-06396
	DRP-4221 Trunnion Roll Shaft	050-6-06401
DRP-4222	Trunnion Roll Shaft	050-6-16070
TRP-166	Ring Gear	050-6-02470
TRP-167	Drive Pinion	050-6-02471
DRP-4216	Angle Flight	050-6-03190
DRP-4217	Angle Flight	050-6-03191

"YOUR HEADQUARTERS FOR ASPHALT PLANT REPLACEMENT PARTS"

C ONSTRUCTION

P ARTS

I NC.®



ORDER
BY PHONE

TOLL FREE
1-800-222-1141

Ohio 1-800-338-5608

FAX 216-524-5682

Telephone 216-524-7100

AVAILABLE REPLACEMENT PARTS
FOR
H & B PLANTS

88" & 100" DRYER

C.P.I. PART NO.	PART DESCRIPTION	REPLACEMENT FOR O.E.M. PART NO.
DRP-4126	Trunnion Ring (Dryer Tire)	050-6-03824
DRP-4131	Trunnion Ring (Dryer Tire)	050-6-15091
DRP-4223	Trunnion Roll Assembly Consists Of:	050-6-15038
	DRP-4224 Trunnion Roll	050-6-03825
	DRP-4225 Trunnion Roll Shaft	050-6-03901
DRP-4226	Trunnion Roll Assembly Consists Of:	050-6-16119
	DRP-4224 Trunnion Roll	050-6-03825
	DRP-4227 Trunnion Roll Shaft	050-6-16042
DRP-4230	Trunnion Roll	050-6-15055
DRP-4231	Trunnion Roll Shaft	050-6-16117
DRP-4228	Angle Flight	050-6-03653
DRP-4229	Angle Flight	050-6-03652

"YOUR HEADQUARTERS FOR ASPHALT PLANT REPLACEMENT PARTS"

C O N S T R U C T I O N

P A R T S

I N C. ®



ORDER BY PHONE

TOLL FREE
1-800-222-1141

Ohio 1-800-338-5608

FAX 216-524-5682 Telephone 216-524-7100

**AVAILABLE REPLACEMENT PARTS
FOR
H & B PLANTS**

112" DRYER

C.P.I. PART NO.	PART DESCRIPTION	REPLACEMENT FOR O.E.M. PART NO.
DRP-4129	Trunnion Ring (Dryer Tire)	050-6-15085
DRP-4232	Trunnion Roll	050-6-15083
DRP-4233	Trunnion Roll Shaft	050-6-15088
DRP-4234	Trunnion Roll Shaft	050-6-15089
DRP-4330	Dryer Flight	050-6-17159
DRP-4331	Dryer Flight	050-6-17158
DRP-4332	Dryer Flight	050-6-17157
DRP-4333	Dryer Flight	050-6-17155
DRP-4334	Dryer Flight	050-6-17156
DRP-4335	Dryer Flight Support Angle	050-6-16976

ELEVATOR
Traction Wheels

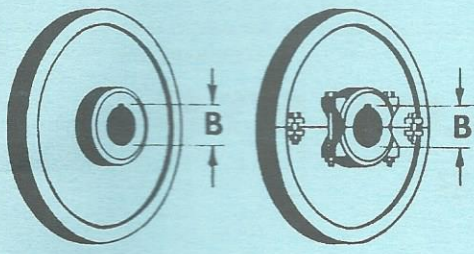

TRACTION WHEELS
Solid Type Split Type

TRACTION WHEELS
COMPLETE W/HUB
(Including Standard Keyway
And Set Screws)

Information Required
To Quote.....

Solid Type _____ Split Type _____
Wheel Diameter _____
Chain Size _____
Bore Diameter "B" _____
(Shaft Diameter)

C.P.I. PART NO.	PART DESCRIPTION	REPLACEMENT FOR O.E.M. PART NO.
ETW-5416	Split Traction Wheel - 18"	150-6-12720
ETW-5417	Split Traction Wheel - 18"	150-6-12721
ETW-5418	Split Traction Wheel - 19 1/4"	150-6-12722
ETW-5419	Split Traction Wheel - 19 1/4"	150-6-12723
ETW-5420	Split Traction Wheel - 21"	150-6-12724
ETW-5421	Split Traction Wheel - 21"	150-6-12725
ETW-5422	Split Traction Wheel - 21"	150-6-12726
ETW-5423	Split Traction Wheel - 21"	150-6-15887
ETW-5424	Split Traction Wheel - 24"	150-6-12727
ETW-5425	Split Traction Wheel - 24"	150-6-12728
ETW-5426	Split Traction Wheel - 24"	150-6-12729
ETW-5427	Split Traction Wheel - 28"	150-6-12730
ETW-5428	Split Traction Wheel - 28"	150-6-12731
ETW-5429	Split Traction Wheel - 28"	150-6-12732
ETW-5430	Split Traction Wheel - 24"	S-856 & 857 Chain
ETW-5431	Split Traction Wheel - 28"	S-856 & 857 Chain

SPROCKET PART NO.	TRACTION WHEEL PART NO.	HUB BODY NO.	BOLT CIRCLE DIAMETER	BOLT SIZE	A	C	D	E
TRP-1010	ETW-1010	CPI-1010	10	1/2	8-1/2	5/8	12-1/4	11-3/4
TRP-1212	ETW-1212	CPI-1212	12	5/8	10-1/2	3/4	14-1/4	13-3/4
TRP-1616	ETW-1616	CPI-1616	16	3/4	14-1/2	3/4	18-1/4	17-3/4
TRP-2020	ETW-2020	CPI-2020	20	3/4	18-1/2	7/8	22-1/4	21-3/4
TRP-2525	ETW-2525	CPI-2525	25	1	23	1	28-1/4	27-3/4

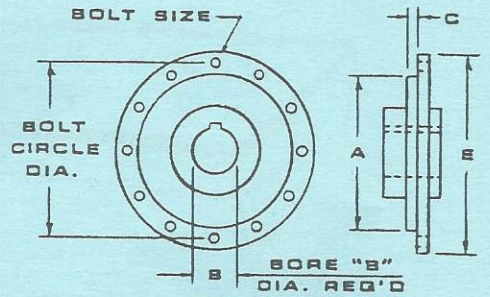

BODY HUB
Sprocket/Traction Wheel

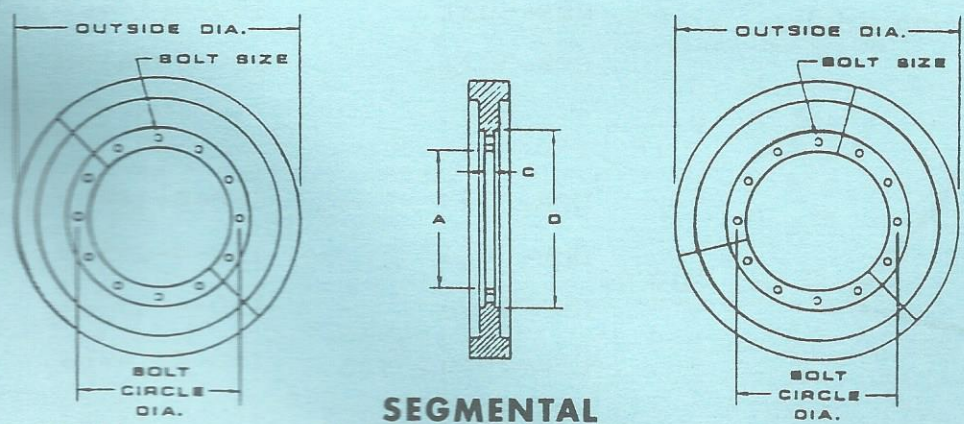

(2) SEGMENTS **SEGMENTAL TRACTION WHEELS** (3) SEGMENTS

TRACTION WHEELS
To Order, Specify

Outside Dia. _____
Chain Size _____
(2) Segments _____
or
(3) Segments _____
Bore Diameter "B" _____
(Shaft Diameter)



ORDER
BY PHONE

TOLL FREE
1-800-222-1141

Ohio 1-800-338-5608

FAX 216-524-5682

Telephone 216-524-7100

STEEL ELEVATOR BUCKETS FOR H & B PLANTS

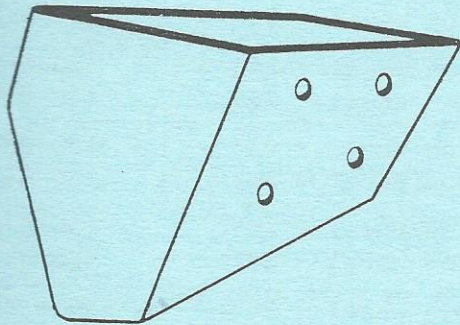

Style "AC"

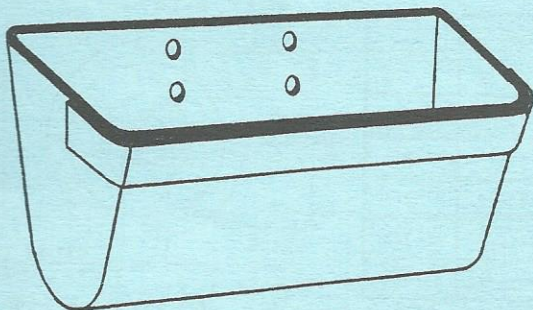

Style "AA" (with reinforcing strip)

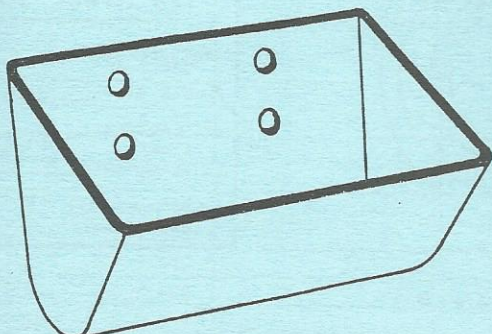

Style "A"

C.P.I.
PART No.

REPLACEMENT FOR
O.E.M. PART No.

HEB-5000	16817
HEB-5004	16864
HEB-5010	16681 or 16683
HEB-5012	16680
HEB-5013	17117
HEB-5065	050-6-17022
HEB-5014	150-4-15864
HEB-5015	150-4-14470
HEB-5016	150-4-15705
HEB-5017	150-4-15550
HEB-5018	150-4-14467
HEB-5019	150-4-16239
HEB-5020	150-4-15863
HEB-5021	150-4-14462
HEB-5022	150-4-16108
HEB-5023	150-4-14469
HEB-5024	150-4-15598
HEB-5025	150-4-15632
HEB-5026	150-4-14464
HEB-5027	150-4-14459

"YOUR HEADQUARTERS FOR ASPHALT PLANT REPLACEMENT PARTS"